



SERVICE AND OPERATING MANUAL



II 2GD b T5



Model SA1-A

Model SA25A

Type 4

PLEASE NOTE!

The photos shown in this manual are for general instruction only. Your specific model may not be shown. Always refer to the parts list and exploded view drawing for your specific model when installing, disassembling or servicing your pump.

PRINCIPLE OF PUMP OPERATION

This flap swing check valve pump is powered by compressed air and is a 1:1 pressure ratio design. It alternately pressurizes the inner side of one diaphragm chamber, while simultaneously exhausting the other inner chamber. This causes the diaphragms, which are connected by a common rod, to move endwise. Air pressure is applied over the entire surface of the diaphragm, while liquid is discharged from the opposite side. The diaphragm operates under a balanced condition during the discharge stroke, which allows the unit to be operated at discharge heads over 200 feet (61 meters) of water head.

Since the diaphragms are connected by a common rod, secured by plates to the center of the diaphragms, one diaphragm performs the discharge stroke, while the other is pulled to perform the suction stroke in the opposite chamber.

For maximum diaphragm life, keep the pump as close to the liquid being pumped as possible. Positive suction head in excess of 10 feet of liquid (3.048 meters) may require a back pressure regulating device. This will maximize diaphragm life.

Alternate pressuring and exhausting of the diaphragm chamber is performed by means of an externally mounted, pilot operated, four-way spool type air distribution valve. When the spool shifts to one end of the valve body, inlet air pressure is applied to one diaphragm chamber and the other diaphragm chamber exhausts. When the spool shifts to the opposite end of the valve body, the porting of chambers is reversed. The air distribution valve spool is moved by an internal pilot valve which alternately pressurizes one side of the air distribution valve spool, while exhausting the other side. The pilot valve is shifted at each end of the diaphragm stroke by the diaphragm plate coming in contact with the end of the pilot valve spool. This pushes it into position for shifting of the air distribution valve.

The chambers are manifolded together with a suction and discharge check valve for each chamber, maintaining flow in one direction through the pump.

INSTALLATION & START-UP

Locate the pump as close to the product being pumped as possible, keeping suction line length and number of fittings to a minimum. Do not reduce line size.

For installations of rigid piping, short flexible sections of hose should be installed between pump and piping. This reduces vibration and strain to the piping system. A Warren Rupp Tranquilizer® surge suppressor is recommended to further reduce pulsation in flow.

This pump was tested at the factory prior to shipment and is ready for operation. It is completely self-priming from a dry start for suction lifts of 5-7 feet (1.5-2 meters) or less. For suction lifts exceeding 10 feet of liquid, fill the chambers with liquid prior to priming.

CHAMBER PORTING

SA1-A with bottom chamber porting of check valve manifolding is recommended for general portable pumping applications, low head transfer pumping, and for pumping solids-laden liquids which tend to settle out.

For low flow, high pressure applications and for pumping highly viscous liquids, top porting of chamber to check valve manifold is recommended. Model SA1-A SandPIPER with flap type valves can be arranged in either bottom chamber porting or top chamber porting of check valve manifold simply by rotating outer diaphragm chambers 180° and reversing the flap valves and seats in the manifold so they

IMPORTANT

Read these instructions completely, before installation and start-up. It is the responsibility of the purchaser to retain this manual for reference. Failure to comply with the recommendations stated in this manual will damage the pump, and void factory warranty.

WARNING

Take action to prevent static sparking. Fire or explosion can result, especially when handling flammable liquids. The pump, piping, valves, containers or other miscellaneous equipment must be grounded. (See page 6)

BEFORE OPERATION

Before pump operation, inspect all gasketed fasteners for looseness caused by gasket creep. Retorque loose fasteners to prevent leakage. Follow recommended torques stated in the card attached to the new pump.

DANGER

Before doing any maintenance on the pump, be certain all pressure is completely vented from the pump, suction, discharge, piping, and all other openings and connections. Be certain the air supply is locked out or made non-operational, so that it cannot be started while work is being done on the pump. Be certain that approved eye protection and protective clothing are worn all times in the vicinity of the pump. Failure to follow these recommendations may result in serious injury or death.

HAZARD WARNING

POSSIBLE EXPLOSION HAZARD can result if 1, 1, 1,-Trichloroethane, Methylene Chloride or other Halogenated Hydrocarbon solvents are used in pressurized fluid systems having Aluminum or Galvanized wetted parts. Death, serious bodily injury and/or property damage could result. Consult with the factory if you have questions concerning Halogenated Hydrocarbon solvents.

remain in the proper operating position—hanging downward. Make certain that the flap valves are opening outward from the manifold.

Note: Low profile mounting feet are available when the top porting configuration is used.

AIR SUPPLY

Air supply pressures cannot exceed 125 psi (8.61 bar). Connect the pump air inlet to an air supply of sufficient capacity and pressure required for desired performance. When the air line is solid piping, use a short length of flexible hose (not less than 3/4" (19mm) in diameter) between pump and piping to eliminate strain to pipes. Use of a Warren Rupp Filter/Regulator in the air line is recommended.

AIR INLET & PRIMING

For start-up, open an air valve approximately 1/4" to 1/2" turn. After the unit primes, an air valve can be opened to increase flow as desired. If opening the valve increases cycling rate, but does not increase flow rate, cavitation has occurred, and the valve should be closed slightly.

For the most efficient use of compressed air and the longest diaphragm life, throttle the air inlet to the lowest cycling rate that does not reduce flow.

AIR EXHAUST

If a diaphragm fails, the pumped liquid or fumes can enter the air end of the pump, and be exhausted into the atmosphere. When pumping hazardous or toxic materials, pipe the exhaust to an appropriate area for safe disposition.

This pump can be submerged if materials of construction are compatible with the liquid. The air exhaust must be piped above the liquid level. Piping used for the air exhaust must not be smaller than 1" (2.54 cm). Reducing the pipe size will restrict air flow and reduce pump performance. When the product source is at a higher level than the pump (flooded suction), pipe the exhaust higher than the product source to prevent siphoning spills.

Freezing or icing of the air exhaust can occur under certain temperature and humidity conditions. Use of an air dryer should eliminate most icing problems.

BETWEEN USES

When used for materials that tend to settle out or transform to solid form, the pump should be completely flushed after each use, to prevent damage. Product remaining in the pump between uses could dry out or settle out. This could cause problems with valves and diaphragms at re-start. In freezing temperatures, the pump must be drained between uses in all cases.

CHECK VALVE SERVICING

Need for inspection or service is usually indicated by poor priming, unstable cycling, reduced performance or the pump's cycling but not pumping.

Remove the six flange bolts securing the inlet and outlet flanges to the manifold. Inspect the surfaces of both check valve and seat for wear or damage that could prevent proper sealing. If pump is to prime properly, valves must seat air tight.

Flap type models can be assembled with the manifold positioned under the diaphragm chamber (bottom porting) or above (top porting). Inlet and outlet flange pipe threads run horizontal in either case. Flap valves and seats must be reassembled to unit to conform to the "IN" and "OUT" markings on the base plate. Install the valve seat and flap valve on the side of the unit marked "OUT" with the flap valve hanging down and swinging away from the manifold into the flange. Install the flap valve and seat on the other side of the unit marked "IN" with the flap valve hanging down and swinging into the manifold, away from the flange. Inlet and outlet direction is determined by how the check valves are installed.

DIAPHRAGM SERVICING

Remove the four bolts securing the manifold flange to the chamber. Remove the eight nuts securing the outer diaphragm chamber flange and remove the chamber. Loosen the capscrew securing the diaphragm and plate to the rod by leaving the diaphragm engaged with the capscrews around the outer flange, preventing rotation of the rod. **DO NOT USE A WRENCH ON THE DIAPHRAGM ROD. FLAWS ON THE SURFACE MAY DAMAGE BEARINGS AND SEAL.**

During reassembly make certain that the rubber bumper is on the rod on each side. Install the diaphragm with the natural bulge outward as indicated on the

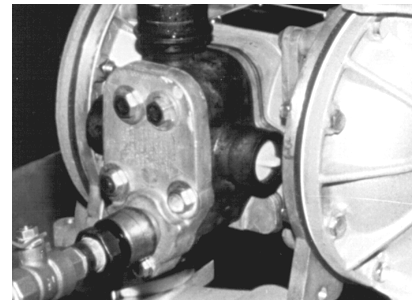

Air Inlet

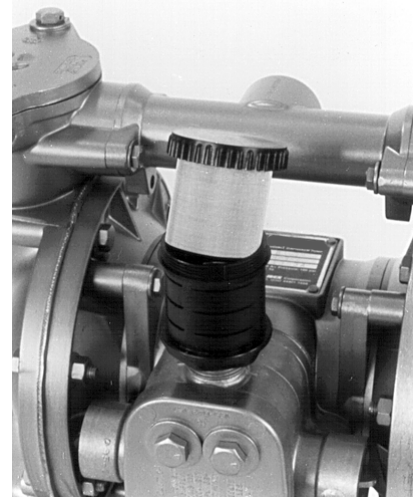

Check exhaust muffer for ice buildup/air contaminants.

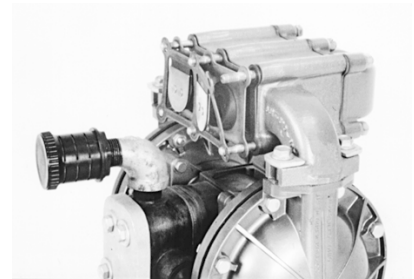

Flap valve.

diaphragm. Install the heavier plate on the outside of the diaphragm and make certain that the large radius side of both plates are toward the diaphragm. Place the sealing washer between the inner diaphragm plate and the end of the rod. Tighten the capscrew to approximately 25 ft. lbs. (33.9 Newton meters). Torque while allowing diaphragm to turn freely with plates, except for EPDM rubber, use a light weight oil between the plates and diaphragm when doing this procedure. Use a wrench on the capscrew of the opposite side to keep the rod from rotating. If the opposite chamber is assembled, the rod need not be held.

When reassembling the outer chambers and the manifold, the bolts securing the manifold flange to the chamber should be snugged prior to tightening the chamber bolts.

The sleeve and spool set is located in the valve body, which is held onto the intermediate bracket by four (4) capscrews. Loosening the four (4) hex head capscrews allows the valve body to come out of place.

Once the valve body is off the pump, remove the retaining ring holding the endcap on the body to inspect the spool and sleeve set. The spool of the air distribution valve is closely sized to the sleeve. The spool must slide freely in the sleeve. Accumulation of dirt and contaminants may prevent the spool from moving freely. It may stick in a position that prevents the pump from cycling.

Clean all parts before reassembly. Use a safety solvent and air oil to keep the parts from oxidizing. Any nicks on the spool should be removed with a fine stone or crocus cloth.

When removing the stainless steel sleeve, carefully press it out of the body, preferably using an arbor press. Reinstall it into the body until it bottoms out against the opposite endcap. Use new o-rings when reinstalling and apply a light coating of grease or o-ring lube before placing in the valve body.

Reinstall the spring, endcap, and new retaining rings. Tighten the four capscrews to eliminate air leakage. Tighten at 150 in/lbs (16.9 newton meters). Reinstall the body on the intermediate bracket with new gaskets.

A NOTE ABOUT AIR VALVE LUBRICATION

The SandPiper pump's pilot and main air valve assemblies are designed to operate WITHOUT lubrication. This is the preferred mode of operation. There may be instances of personal preference, or poor quality air supplies when lubrication of the compressed air supply is required. The pump air system will operate with properly lubricated compressed air supplies. Proper lubrication of the compressed air supply would entail the use of an air line lubricator (available from Warren Rupp) set to deliver one drop of 10 wt., non-detergent oil for every 20 SCFM of air the pump consumed at its point of operation. Consult the pump's published Performance Curve to determine this.

It is important to remember to inspect the sleeve and spool set routinely. It should move back and forth freely. This is most important when the air supply is lubricated. If a lubricator is used, oil accumulation will, over time, collect any debris from the compressed air. This can prevent the pump from operating properly.

Water in the compressed air supply can create problems such as icing or freezing of the exhaust air causing the pump to cycle erratically, or stop operating. This can be addressed by using a point of use air dryer to supplement a plant's air drying equipment. This device will remove excess water from the compressed air supply and alleviate the icing or freezing problem.

ESADS: Externally Serviceable Air Distribution System

Please refer to the exploded view drawing and parts list in the Service Manual supplied with your pump. If you need replacement of additional copies, contact your local Warren Rupp Distributor, or the Warren Rupp factory Literature Department at the number shown below. To receive the correct manual, you must specify the MODEL and TYPE information found on the name plate of the pump.

Models with 1" suction/discharge or larger and METAL center sections

The main air valve sleeve and spool set is located in the valve body mounted on the pump with four hex head capscrews. The valve body assembly is removed from the pump by removing these four hex head capscrews.

With the valve body assembly off the pump, access to the sleeve and spool set is made by removing four hex head capscrews (each end) on the end caps of the valve body assembly. With the end caps removed, slide the spool back and forth in the sleeve. The spool is closely sized to the sleeve and must move freely to allow for

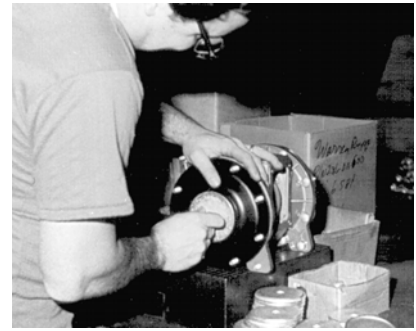

Diaphragm

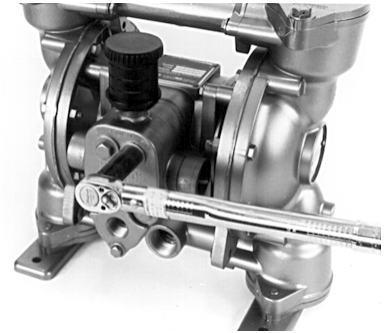

Torquing cap screws

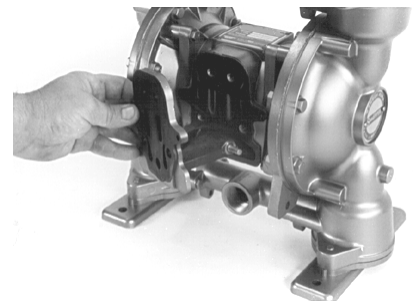

Pilot valve

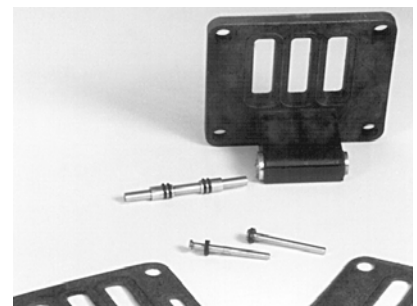

Pilot valve body spool plungers



Bushings, retaining rings and o-rings

proper pump operation. An accumulation of oil, dirt or other contaminants from the pump's air supply, or from a failed diaphragm, may prevent the spool from moving freely. This can cause the spool to stick in a position that prevents the pump from operating. If this is the case, the sleeve and spool set should be removed from the valve body for cleaning and further inspection.

Remove the spool from the sleeve. Using an arbor press or bench vise (with an improvised mandrel), press the sleeve from the valve body. Take care not to damage the sleeve. At this point, inspect the o-rings on the sleeve for nicks, tears or abrasions. Damage of this sort could happen during assembly or servicing. A sheared or cut o-ring can allow the pump's compressed air supply to leak or bypass within the air valve assembly, causing the pump to leak compressed air from the pump air exhaust or not cycle properly. This is most noticeable at pump dead head or high discharge pressure conditions. Replace any of these o-rings as required or set up a routine, preventive maintenance schedule to do so on a regular basis. This practice should include cleaning the spool and sleeve components with a safety solvent or equivalent, inspecting for signs of wear or damage, and replacing worn components.

To re-install the sleeve and spool set, lightly lubricate the o-rings on the sleeve with an o-ring assembly lubricant or lightweight oil (such as 10 wt. air line lubricant). Re-install one end cap, and retaining ring (see safety warning) on the valve body. Using the arbor press or bench vise that was used in disassembly, carefully press the sleeve back into the valve body, without shearing the o-rings. You may have to clean the surfaces of the valve body where the end caps mount. Material may remain from the old gasket. Old material not cleaned from this area may cause air leakage after reassembly. Take care that the bumper stays in place allowing the sleeve to press in all the way. Reinstall the spool, opposite end cap and retaining ring (see safety warning) on the valve body. After inspecting and cleaning the gasket surfaces on the valve body and intermediate, reinstall the valve body on the pump using new gaskets. Tighten the four hex head capscrews evenly and in an alternating cross pattern.

PILOT VALVE

The pilot valve assembly is accessed by removing the main air distribution valve body from the pump and lifting the pilot valve body out of the intermediate housing.

Most problems with the pilot valve can be corrected by replacing the o-rings. Always grease the spool prior to inserting it into the sleeve. If the sleeve is removed from the body, reinsertion must be at the chamfered side. Grease the o-rings to slide the sleeve into the valve body. Securely insert the retaining ring around the sleeve. When reinserting the pilot valve, push both plungers (located inside the intermediate bracket) out of the path of the pilot valve spool ends to avoid damage.

PILOT VALVE ACTUATOR

Bushings for the pilot valve actuators are held in the inner chambers with retaining rings. An o-ring is behind each bushing. If the plunger has any sideways motion, check o-rings and bushings for deterioration/wear. The plunger may be removed for inspection or replacement. First remove the air distribution valve body and the pilot valve body from the pump. The plungers can be located by looking into the intermediate. It may be necessary to use a fine piece of wire to pull them out. The bushing can be turned out through the inner chamber by removing the outer chamber assembly. Replace the bushings if pins have bent.

TROUBLE SHOOTING

1. Pump will not cycle

- Check to make sure the unit has enough pressure to operate and that the air inlet valve is open.
- Check the discharge line to insure that the discharge line is neither closed nor blocked.
- If the spool in the air distribution valve is not shifting, check the main spool. It must slide freely.
- Excessive air leakage in the pump can prevent cycling. This condition will be evident. Air leakage into the discharge line indicates a ruptured diaphragm. Air leakage from the exhaust port indicates leakage in the air distribution valve. See further service instructions.
- Blockage in the liquid chamber can impede movement of diaphragm.

⚠ IMPORTANT ⚠

This pump is pressurized internally with air pressure during operation. Always make certain that all bolting is in good condition and that all of the correct bolting is reinstalled during assembly.

⚠ CAUTION ⚠

If a diaphragm fails the pumped product or fumes can enter the air side of the pump. This side is exhausted through the exhaust port (muffler).

When the product is a hazardous or toxic material, the exhaust should be piped to an appropriate area for safe disposition.

When the product source is at a higher level than the pump (flooded suction), the exhaust should be piped to a higher level than the product to prevent spills caused by siphoning.

⚠ SAFETY WARNING ⚠

To assure proper pump function and safe installation of the retaining ring, check the gap "G" dimension for full installation into the valve body grooves.

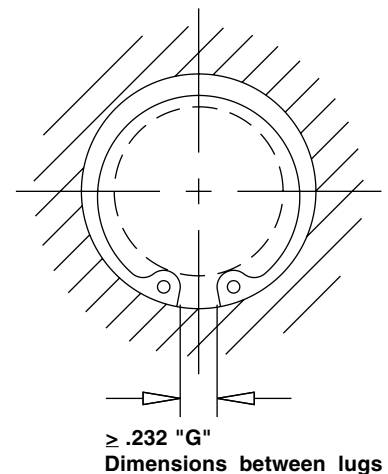

2. Pump cycles but will not pump

A. Suction side of pump pulling in air. Check the suction line for air leaks and be sure that the end of the suction line is submerged. Check flange bolting. Check valve flanges and manifold to chamber flange joints.

B. Make certain the suction line or strainer is not plugged. Restriction at the suction is indicated by a high vacuum reading when a vacuum gauge is installed in the suction line.

C. Check valves may not be seating properly. To check, remove the suction line and cover the suction port with your hand. If the unit does not pull a good suction (vacuum), the check valves should be inspected for proper seating.

D. Static suction lift may be too high. Priming can be improved by elevating the suction and discharge lines higher than the check valves and pouring liquid into the unit through the suction inlet. When priming at high suction lifts or with long suction lines operate the pump at maximum cycle rate.

3. Low performance

A. Capacity is reduced as the discharge pressure increases, as indicated on the performance curve. Performance capability varies with available inlet air supply. Check air pressure at the pump inlet when the pump is operating to make certain that adequate air supply is maintained.

B. Check vacuum at the pump suction. Capacity is reduced as vacuum increases. Reduced flow rate due to starved suction will be evident when cycle rate can be varied without change in capacity. This condition will be more prevalent when pumping viscous liquids. When pumping thick, heavy materials (10,000 SSU limit), the suction line must be kept as large in diameter and as short as possible, to keep suction loss minimal.

C. Low flow rate and slow cycling rate indicate restricted flow through the discharge line. Low flow rate and fast cycling rate indicate restriction in the suction line or air leakage into suction.

NOTE: Bottom chamber porting on the SA1-A pump for thick liquids may create an air trap in the outer liquid chamber, causing reduced displacement and low capacity performance. Use of air vent lines from the top of the chamber back to the liquid source will correct this. Converting to top chamber porting will eliminate any possibility of an air trap in the liquid chambers.

D. Unstable cycling indicates improper check valve seating on one chamber. This condition is confirmed when unstable cycling repeats consistently on alternate exhausts. Cycling that is not consistently unstable may indicate partial exhaust restriction due to freezing and thawing of exhaust air. Use of an air dryer should solve this problem.

WARRANTY

This pump is warranted for a period of five years against defective material and workmanship. Failure to comply with the recommendations stated in this manual voids all factory warranty.

RECOMMENDED WARREN RUPP ACCESSORIES TO MAXIMIZE PUMP PERFORMANCE:

- **Tranquilizer® Surge Suppressor. For nearly pulse-free flow.**
- **Warren Rupp Filter/Regulator. For modular installation and service convenience.**
- **Warren Rupp Speed Control. For manual or programmable process control. Manual adjustment or 4-20mA reception.**

For more detailed information on these accessories, contact your local Warren Rupp Factory-Authorized Distributor, or Warren Rupp corporate headquarters.

©2004 Warren Rupp, Inc. All rights reserved.

®SandPIPER and Tranquilizer are registered tradenames of Warren Rupp, Inc.

®Neverseize is a registered tradename of Loctite

Printed in U.S.A.

Grounding The Pump

! WARNING !

Take action to prevent static sparking. Fire or explosion can result, especially when handling flammable liquids. The pump, piping, valves, containers or other miscellaneous equipment must be grounded.

One eyelet is installed to a true earth ground.
(Requires a maximum 5/16 or 8mm maximum diameter blot)

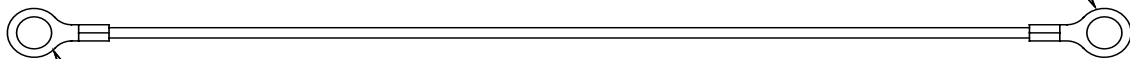

One eyelet is fastened to the pump hardware.

This 8 foot long (224 centimeters) Groundstrap, part number 920-025-000, can be ordered as a service item.

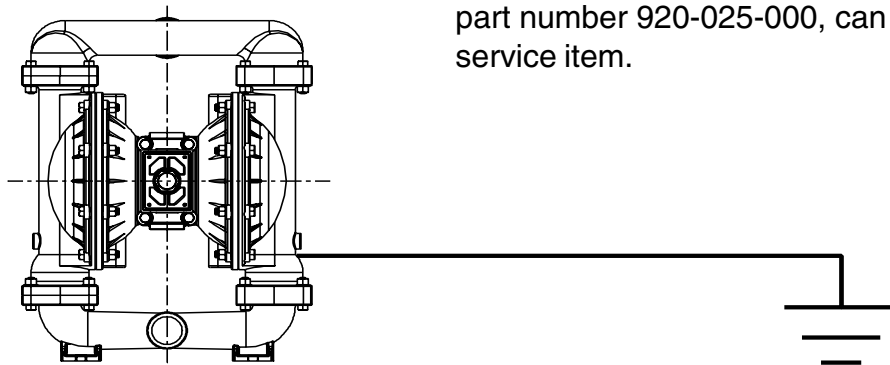

To reduce the risk of static electrical sparking, this pump must be grounded. Check the local electrical code for detailed grounding instruction and the type of equipment required, or in the absence of local codes, an industry or nationally recognized code having jurisdiction over specific installations.



SERVICE AND OPERATING MANUAL



II 2GD b T5



Model SA1-A Model SA25A Type 4

ITEM NO.	PART NUMBER	DESCRIPTION	TOTAL RQD.
1	165-042-157	Cap, Valve Body (AL Center)	1
	165-042-558	Cap, Valve Body (CI Center)	1
2	360-058-360	Gasket, Valve Cap	1
3	170-063-330	Capscrew, Hex Head	1
4	170-033-330	Capscrew, Hex Head	4
5	901-035-330	Washer, Flat (AL Center)	7
	901-035-330	Washer, Flat (CI Center)	1
	900-005-330	Washer, Lock (CI Center)	6
6	901-005-330	Washer, Flat	4
7	542-001-330	Nut, Square	1
8	095-051-558	Body, Spool Valve	1
9	031-039-000	Sleeve & Spool Set	1
10	165-038-356	Cap, End	2
11	675-043-115	Ring, Retainer	2
12	560-058-360	O-Ring	8
13	360-057-360	Gasket	1
14	095-074-000	Assembly, Pilot Valve*	1
14-A	095-071-551	Valve Body	1
14-B	755-025-000	Sleeve (without O-Ring)	1
14-C	560-033-360	O-Ring (Sleeve)	4
14-D	775-014-000	Spool (without O-Ring)	1
14-E	560-023-360	O-Ring (Spool)	4
14-F	675-037-080	Retaining Ring	1
15	360-056-360	Gasket	1
16	114-007-157	Bracket, Intermediate (AL Center)	1
	114-012-010	Bracket, Intermediate (CI Center)	1
17	560-040-360	O-Ring	2
18	675-040-360	Ring, Sealing (AL Center)	2
19	720-010-375	Seal, U-Cup	2
20	070-012-170	Bearing, Sleeve	2
21	685-039-120	Rod, Diaphragm	1
22	901-012-180	Washer, Sealing	2
23	170-034-330	Capscrew, Hex Head	2
24	900-003-330	Washer, Lock (AL Wetted)	2
25	612-023-330	Plate, Outer	2
	612-101-110	Plate, Outer**	2
26	286-008-354	Diaphragm	2
	286-008-356	Diaphragm	2
	286-008-360	Diaphragm	2
	286-008-363	Diaphragm	2
	286-008-364	Diaphragm	2
	286-008-365	Diaphragm	2
27	612-022-330	Plate, Inner	2
28	132-019-360	Bumper	2
29	196-043-157	Chamber, Inner (left side) (AL Center)	1
	196-084-010	Chamber, Inner (left side) (CI Center)	1
30	196-042-157	Chamber, Inner (right side) (AL Center)	1
	196-090-010	Chamber, Inner (right side) (CI Center)	1
31	620-007-114	Plunger, Actuator	2
32	560-001-360	O-Ring	2
33	135-034-506	Bushing	2
34	675-042-115	Ring, Retainer	2
35	170-043-330	Capscrew, Hex Head (AL Center)	6
	170-006-330	Capscrew, Hex Head (CI Center)	6
36	196-012-157	Chamber, Outer	2
	196-012-110	Chamber, Outer	2
37	170-029-330	Capscrew, Hex Head	16

Repair Parts shown in **bold face (darker)** type are more likely to need replacement after extended periods of normal use. They are readily available from most Warren Rupp distributors. The pump owner may prefer to maintain a limited inventory of these parts in his own stock to reduce repair downtime to a minimum.

IMPORTANT: When ordering repair parts always furnish pump model number, serial number and type number.

MATERIAL CODES The Last 3 Digits of Part Number

- 000...Assembly, sub-assembly; and some purchased items
 - 010...Cast Iron
 - 012...Powered Metal
 - 015...Ductile Iron
 - 020...Ferritic Malleable Iron
 - 025...Music Wire
 - 080...Carbon Steel AISI B-112
 - 100...Alloy 20
 - 110...Alloy Type 316 Stainless Steel
 - 111...Alloy Type 316 Stainless Steel (Electro Polished)
 - 112...Alloy "C"
 - 113...Alloy Type 316 Stainless Steel (Hand Polished)
 - 114...303 Stainless Steel
 - 115...302/304 Stainless Steel
 - 117...440-C Stainless Steel (Martensitic)
 - 120...416 Stainless Steel (Wrought Martensitic)
 - 123...410 Stainless Steel (Wrought Martensitic)
 - 148...Hardcoat Anodized Aluminum
 - 149...2024-T4 Aluminum
 - 150...6061-T6 Aluminum
 - 151...6063-T6 Aluminum
 - 152...2024-T4 Aluminum (2023-T351)
 - 154...Almag 35 Aluminum
 - 155 or 156...356-T6 Aluminum
 - 157...Die Cast Aluminum Alloy #380
 - 158...Aluminum Alloy SR-319
 - 159...Anodized Aluminum
 - 162...Brass, Yellow, Screw Machine Stock
 - 165...Cast Bronze, 85-5-5-5
 - 166...Bronze SAE 660
 - 170...Bronze, Bearing Type, Oil Impregnated
 - 180...Copper Alloy
 - 310...Kynar Coated
 - 330...Zinc Plated Steel
 - 331...Chrome Plated Steel
 - 332...Electroless Nickel Plated
 - 335...Galvanized Steel
 - 336...Zinc Plated Yellow Brass
 - 337...Silver Plated Steel
 - 340...Nickel Plated
 - 342...Filled Nylon
 - 354...Injection Molded #203-40 Santoprene
- Duro 40D ± 5; Color: RED
 - 355...Thermoplastic Elastomer
 - 356...Hytre
 - 357...Rupplon (Urethane Rubber) Color coded: PURPLE
 - 358...Rupplon (Urethane Rubber) Color coded: PURPLE
(Some Applications, Compression Mold)
 - 359...Urethane Rubber
 - 360...Buna-N Rubber Color coded: RED
 - 361...Buna-N
 - 363...Viton (Fluorel) Color coded: YELLOW
 - 364...E.P.D.M. Rubber Color coded: BLUE
 - 365...Neoprene Rubber Color coded: GREEN
 - 370...Butyl Rubber Color coded: BROWN
 - 371...Phlthane (Tuftane)
- List continued next page*

ITEM NO.	PART NUMBER	DESCRIPTION	TOTAL RQD.
38	545-004-330	Nut, Hex	20
39	115-071-080	Foot Bracket	1
	115-070-330	Foot Bracket (Top Ported)	1
41***	706-013-330	Screw, Machine	4
42***	350-002-360	Foot, Rubber	4
43***	547-002-330	Nut, Stop	4
44	618-003-330	Plug, Pipe	3
44A	618-003-330	Plug, Pipe	2
	618-003-110	Plug, Pipe	2
45	132-022-360	Bumper, Actuator	2
46	312-017-335	90 Elbow 3/4" NPT (Exhaust Port) (used w/Top Ported Manifold)	1
47	170-045-330	Capscrew, Hex Head	4
48	518-015-156	Manifold	1
	518-015-110	Manifold	1
	518-059-156	Manifold (Dual Ported)	1
49	338-007-360	Flap Valve	2
	338-007-363	Flap Valve	2
	338-007-364	Flap Valve	2
	338-007-365	Flap Valve	2
50	722-021-360	Valve Seat	2
	722-021-363	Valve Seat	2
	722-021-364	Valve Seat	2
	722-021-365	Valve Seat	2
51	360-031-379	Gasket	2
	360-031-384	Gasket	2
	360-031-608	Gasket	2
52	334-013-157	Flange, Porting	2
	334-013-110	Flange, Porting	2
	334-036-156	Flange, Dual Ported	2
	334-036-110	Flange, Dual Ported	2
	334-013-157E	Flange, Porting BSP	2
	334-013-110E	Flange, Porting BSP	2
	334-036-156E	Flange, Dual Ported BSP	2
	334-036-110E	Flange, Dual Ported BSP	2
53	171-010-330	Capscrew, Flanged	4
54	905-001-015	Washer, Taper	4
55	360-030-425	Gasket, Manifold	2
	360-030-600	Gasket, Manifold (use with Viton or TFE)	2
56	807-029-330	Stud	12
	807-029-330	Stud (Dual Porting)	6
	807-054-330	Stud - Longer (Dual Porting)	6
57	900-004-330	Washer, Lock	16
58	545-004-330	Nut, Hex	12
59	530-036-000	Muffler	1
61	545-005-330	Nut, Hex (SS & Alloy C units only)	4
62	255-012-335	Coupling 3/4" NPT (Exhaust Port) (use w/Bottom Ported Manifold)	1
Items Not Shown:			
	031-030-000	Valve Body Assembly (Includes Items: 8, 9, 10, 11 & 12)	1
	535-022-115	Name Plate (AL Outer Chamber Only)	2
	545-005-330	Nut, Hex (S.S. Only)	4
	705-001-330	Drive Screw (AL Outer Chamber only)	4
Optional Item:			
	800-008-000	Strainer (AL Only)	1

*Item 14 available in kit form. Order #031-060-000 which also includes Items 2, 13, 15, 31, & 45.

**Item 25 #612-101-110 does not require Items 23 and 24.

***Items 41, 42 & 43 noted are available in kit form only - Kit #475-221-000.

Repair Parts shown in **bold face (darker)** type are more likely to need replacement after extended periods of normal use. They are readily available from most Warren Rupp distributors. The pump owner may prefer to maintain a limited inventory of these parts in his own stock to reduce repair downtime to a minimum.

IMPORTANT: When ordering repair parts always furnish pump model number, serial number and type number.

MATERIAL CODES

The Last 3 Digits of Part Number

Continued from previous page

375...Fluorinated Nitrile
378...High density Polypropylene
379...Conductive Nitrile
384...Conductive Neoprene
405...Cellulose Fibre
408...Cork and Neoprene
425...Compressed Fibre
426...Blue Gard
440...Vegetable Fibre
465...Fibre
500...Delrin 500
501...Delrin 570
505...Acrylic Resin Plastic
520...Injection Molded PVDF Natural Color
540...Nylon
541...Nylon
542...Nylon
544...Nylon Injection Molded
550...Polyethylene
551...Polypropylene
552...Unfilled Polypropylene
553...Unfilled Polypropylene
555...Polyvinyl Chloride
558...Conductive HDPE
570...Rulon II
580...Ryton
590...Valox
591...Nylatron G-S
592...Nylatron NSB
600...PTFE (virgin material) Tetrafluoroethylene (TFE)
601...PTFE (Bronze and moly filled)
602...Filled PTFE
603...Blue Gylon
604...PTFE
606...PTFE
608...Conductive PTFE
610...PTFE Encapsulated Silicon
611...PTFE Encapsulated Viton

Delrin, Viton and Hytrel are registered tradenames of E.I. DuPont.

Gylon is a registered tradename of Garlock, Inc.

Nylatron is a registered tradename of Polymer Corp.

Rulon II is a registered tradename of Dixon Industries Corporation.

Hastelloy-C is a registered tradename of Cabot Corp.

Ryton is a registered tradename of Phillips Chemical Company.

Valox is a registered tradename of General Electric Company.

Rupplon, SandPIPER, PortaPump, Tranquilizer, and SludgeMaster are registered tradenames of Warren Rupp Inc.

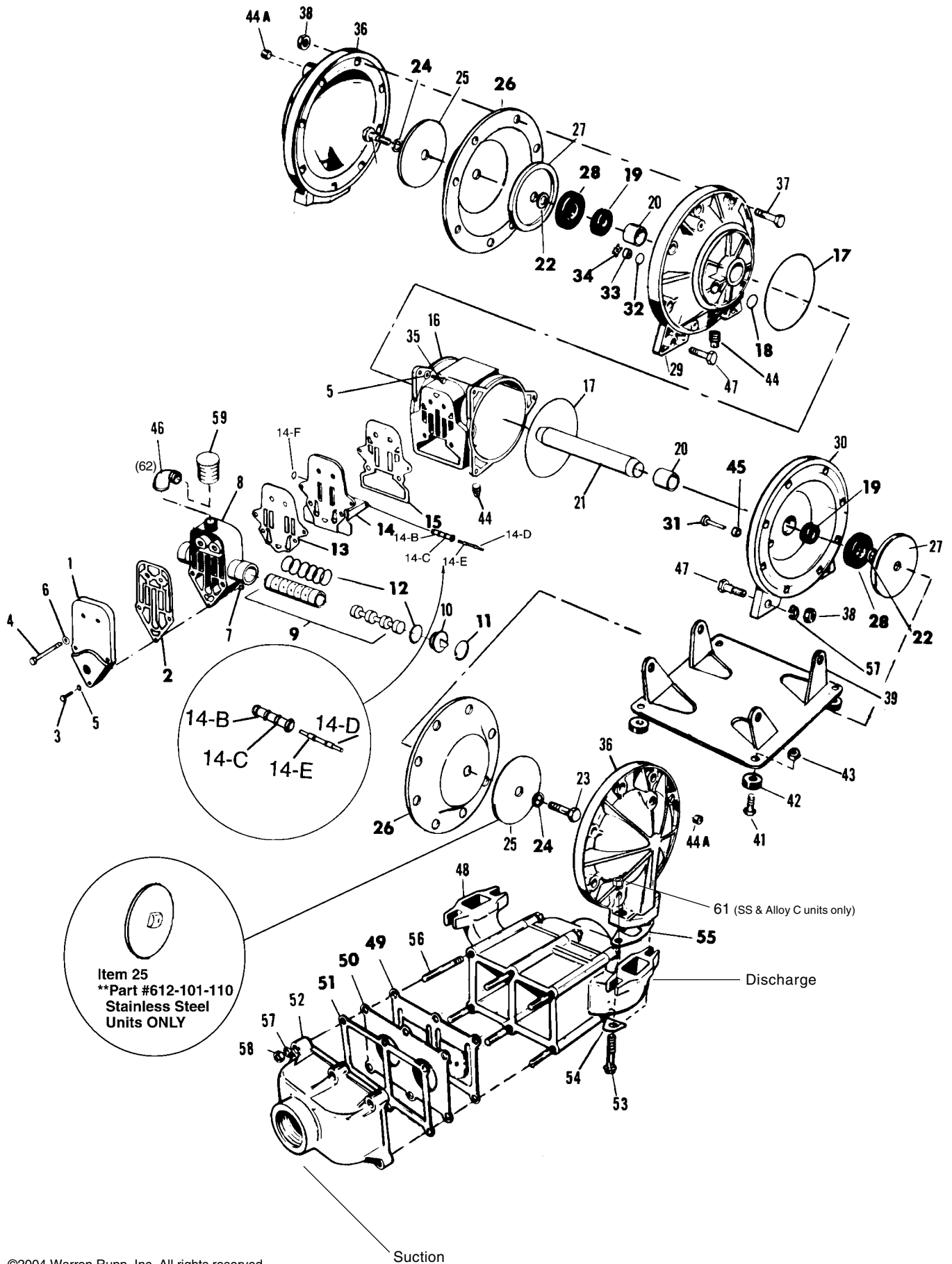

©2004 Warren Rupp, Inc. All rights reserved.

©SandPIPER is a registered trademark of Warren Rupp, Inc.

Printed in U.S.A.

**WARREN
RUPP®**

IDEX
IDEX CORPORATION

Declaration of Conformity ATEX 100a

In accordance with Directive 94/9/EC, Annex VIII Equipment intended for use in potentially explosive environments. Technical File is stored at KEMA, Notified Body 0344, under document number 203040000.

Manufacturer:

Warren Rupp, Inc.
800 North Main Street
P.O. Box 1568
Mansfield, OH 44902 USA

Applicable Standard:

94/9/EC
For potentially explosive environments
Group I, Category M2
Group II, Category 2 GD



Models:

Air-Operated Double Diaphragm Metallic Pumps
Series: G, SA, SB, S, ST, and U under SANDPIPER and MARATHON Brands

SANDPIPER®
A WARREN RUPP PUMP BRAND

MARATHON
A WARREN RUPP PUMP BRAND

DATE/APPROVAL/TITLE: _____

8 May 2003

Rev B 23 October 2003

Jason Awad, VP Engineering